



TOP LEVEL

www.tooplevel.co.rs

RUKOHVATI I LAJSNE
ŠINE I MEHANIZMI

ALU RAMOVI
NOGICE

REŠETKE I LAJSNE
T.L. MODULI

STANDARD PROFILI



TOP LEVEL

Preduzeće **Top Level** počelo je sa radom od 2001. godine. Nalazi se u ulici Šajkaška 3 u Zemunu. U okviru firme nalaze se kancelarije, magacini i proizvodnja. Nastupamo pretežno na trzistu Srbije koje kroz veleprodaju i maloprodaju snabdevamo sa vise inostranih brendova kao i sa artiklima proizvedenim u našoj proizvodnji.

Najistaknutiji program koji zastupamo je program Slovenačkog proizvođača RUJZ design koji je na našem tržištu već dobro poznat. On sadrži veliki izbor ručica za nameštaj, čiviluka, nogica, nosača polica,... To je brend koji odlikuje visoki kvalitet, koji prati svetske trendove i uvek ima da ponudi nešto novo.

2006. godine osnivamo radionicu za obradu aluminijuma koju opremamo najsavremenijim numeričkim mašinama. Tada počinjemo sa proizvodnjom aluminijumskih ramova sa staklenom ispunom. Vremenom proširujemo asortiman tako da sada, pored aluminijumskih frontova, proizvodimo aluminijumska klizna vrata, sistem polica za američke plakare -TL modul, aluminijumske stonice konstrukcije, i još mnogo toga po zhtevu kupca.

U našem maloprodajnom objektu - **CENTAR za STOLARE**, pored gore navedenog imamo veliki izbor najrazličitijeg okova, sudopera, meljača bio otpada, aspiratora, kliznih sistema, lepkova, diht-lajsni,...

Naše poslovanje odlikuje brzina, preciznost, ažurnost, ljubazno osoblje, kao i velike zalihe robe koje dopunjujemo na nedeljnom nivou, što potvrđuje preko 200 zadovoljnih saradnika.



Veleprodaja, proizvodnja i maloprodaja:

Adresa: Šajkaška 3, 11080 Zemun
Telefoni: +381 11 716 79 25
+381 11 716 38 68
Fax: +381 11 716 46 02

Maloprodaja: CENTAR ZA STOLARE 3
Telefon: +381 11 716 71 31

www.toplevel.co.rs

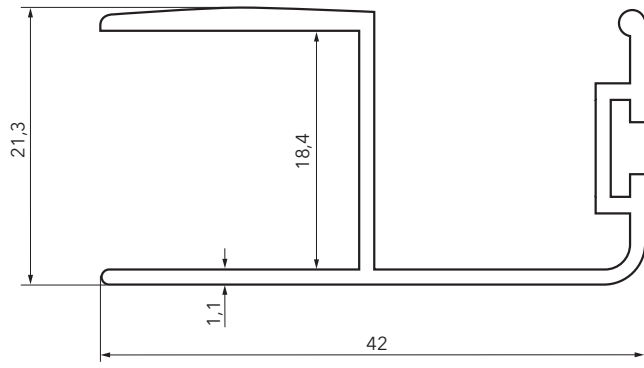

40.01. RUKOHVAT Ć

Kat. broj	Naziv
40.01.01.210	RUKOHVAT Ć
40.01.01.250	RUKOHVAT Ć
40.01.01.270	RUKOHVAT Ć
40.01.03.270	RUKOHVAT Ć

Površinske obrade:

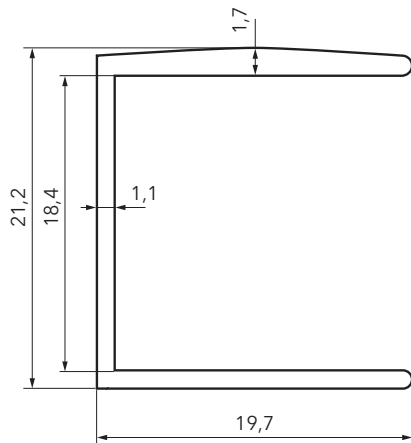
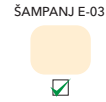

40.02. DUBOKA KANT LAJSNA

Kat. broj	Naziv
40.02.01.210	DUBOKA KANT LAJSNA
40.02.01.250	DUBOKA KANT LAJSNA
40.02.01.270	DUBOKA KANT LAJSNA
40.02.03.270	DUBOKA KANT LAJSNA

Površinske obrade:

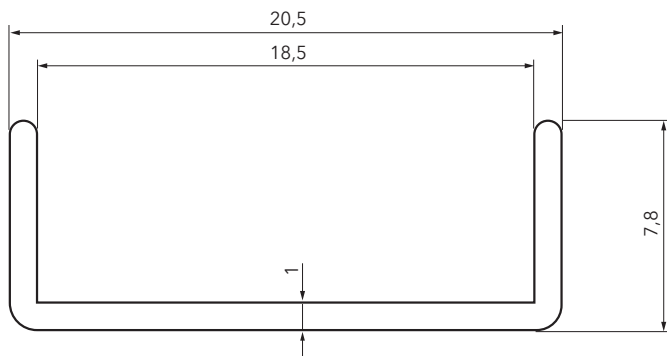
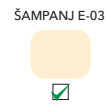

40.03. KANT LAJSNA

Kat. broj	Naziv
40.03.01.300	KANT LAJSNA
40.03.02.300	KANT LAJSNA

Površinske obrade:

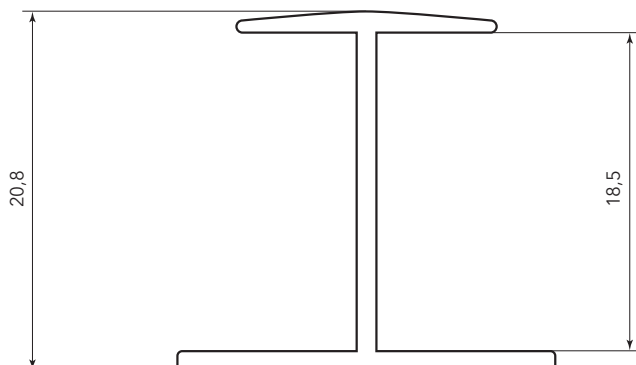

40.04. RUKOHVAT Ć

Kat. broj	Naziv
40.04.01.300	RUKOHVAT Ć

Površinske obrade:



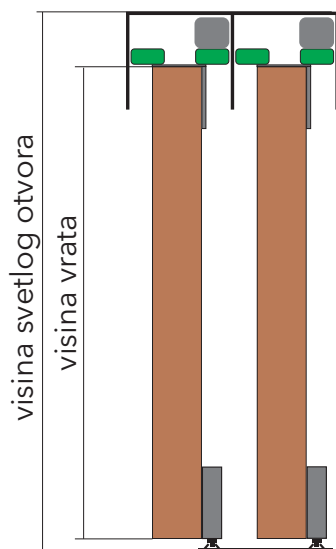
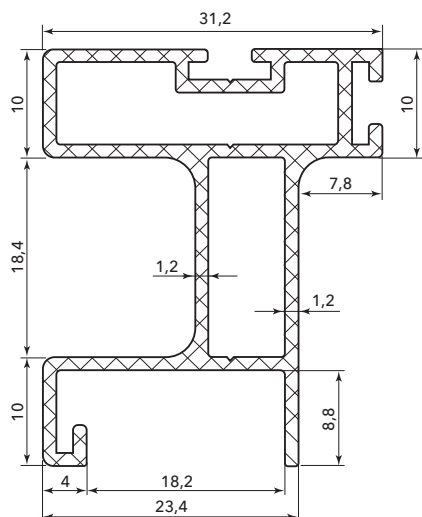
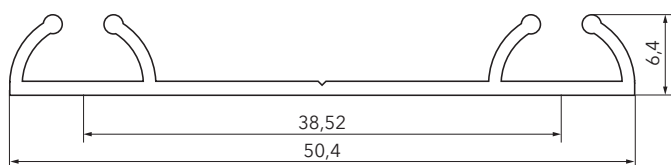
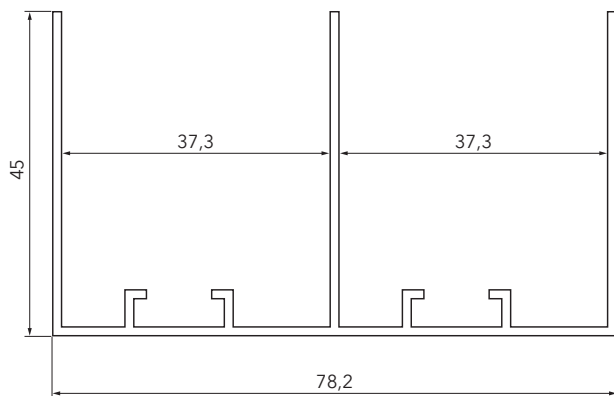

visina svetlog otvora - 5 cm
= visina vrata

20.01. GORNJA ŠINA

Kat. broj	Naziv
20.01.01.600	GORNJA ŠINA
20.01.03.600	GORNJA ŠINA



20.02. DONJA ŠINA

Kat. broj	Naziv
20.02.01.600	DONJA ŠINA
20.02.03.600	DONJA ŠINA



40.05. RUKOHVAT UKF

Kat. broj	Naziv
40.05.01.270	RUKOHVAT UKF MCrE
40.05.03.270	RUKOHVAT UKF Šampanj



50.01. MEHANIZAM UKF ZA 18 mm

Kat. broj	Naziv
50.01.	MEHANIZAM UKF ZA 18 mm

U set ide: 2 x 50.05.00. + 2 x 50.06.00.



Šifra: 50.05.00.



Šifra: 50.06.00.

50.03. USPORIVAČ ZA UKF

Kat. broj	Naziv
50.03.40	USPORIVAČ ZA UKF
50.03.60	
50.03.100	



20.02. DONJA - GORNJA ŠINA

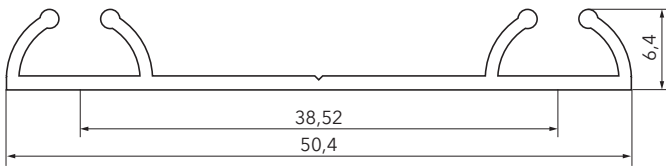

Kat. broj	Naziv
20.02.01.600	DONJA - GORNJA ŠINA
20.02.03.600	DONJA - GORNJA ŠINA

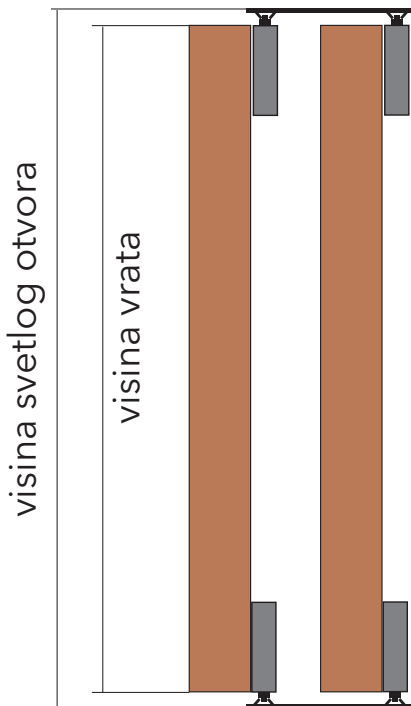

visina svetlog otvora - 1,8 cm
= visina vrata

50.02. MEHANIZAM ECO za 18 mm

Kat. broj	Naziv
50.02.	MEHANIZAM ECO SASTOJI SE IZ 4 KOM 50.06.00.



Šifra: 50.06.00.

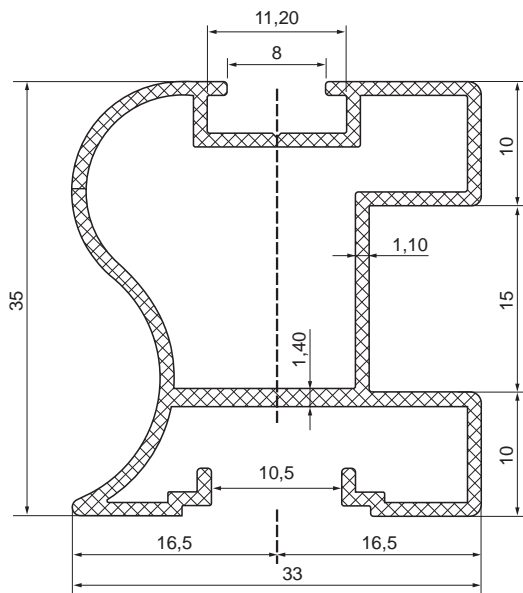

30.01. RUKOHVAT

Kat. broj	Naziv
30.01.01.270	RUKOHVAT ZA 10 mm MAT 270
30.01.01.250	RUKOHVAT ZA 10 mm MAT 250
30.01.03.270	RUKOHVAT ZA 10 mm Šampanj 270
30.01.03.250	RUKOHVAT ZA 10 mm Šampanj 250

Površinske obrade:

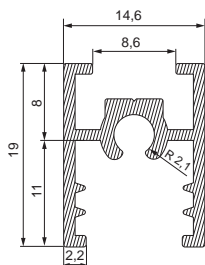

30.02. GORNJA STRANICA

Kat. broj	Naziv
30.02.01.	GORNJA STRANICA MAT
30.02.03.	GORNJA STRANICA ŠAMPANJ

Površinske obrade:



Kat. broj	Naziv
50.09.04.	GUMA ZA VRATA CRNA
50.09.01.	GUMA ZA VRATA SIVA

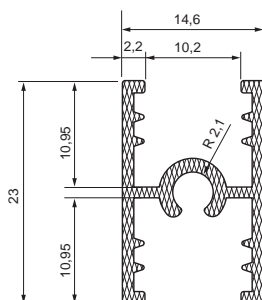

30.03. SREDNJA STRANICA

Kat. broj	Naziv
30.03.01.	SREDNJA STRANICA MAT
30.03.03.	SREDNJA STRANICA ŠAMPANJ

Površinske obrade:

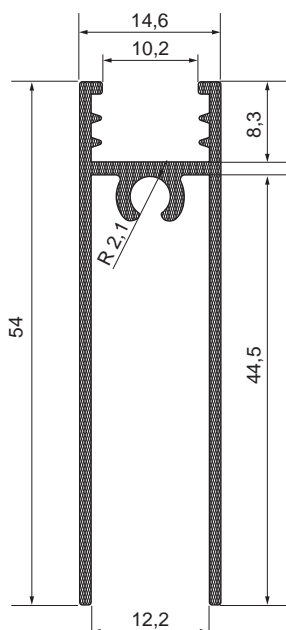

30.04. DONJA STRANICA

Kat. broj	Naziv
30.04.01.	DONJA STRANICA MAT
30.04.03.	DONJA STRANICA ŠAMPANJ

Površinske obrade:

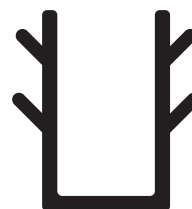

Kat. broj	Naziv
50.08.00.	GUMA ZA STAKLO

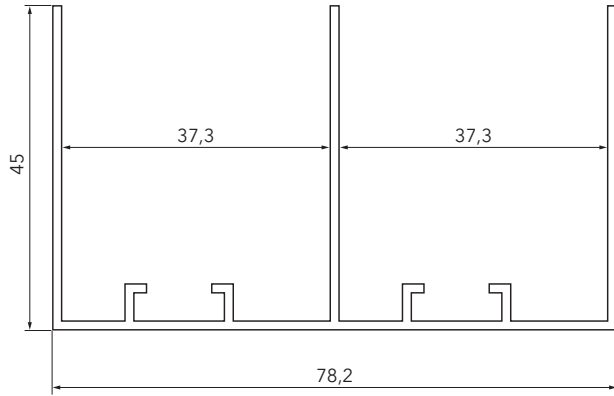

20.01. GORNJA ŠINA

Kat. broj	Naziv
20.01.01.600	GORNJA ŠINA
20.01.03.600	GORNJA ŠINA

Površinske obrade: MAT E-01 ŠAMPANJ E-03

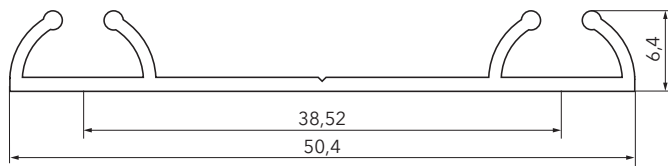

20.02. DONJA ŠINA

Kat. broj	Naziv
20.02.01.600	DONJA ŠINA
20.02.03.600	DONJA ŠINA

Površinske obrade: MAT E-01 ŠAMPANJ E-03



50.12.00. KLIZAČ OMEGA 37



50.14.00.



50.13.00.

Kat. broj	Naziv
50.03.40	USPORIVAČ ZA UKF 20/40
50.03.60	USPORIVAČ ZA UKF 40/60
50.03.100	USPORIVAČ ZA UKF 60/100



10.01. profil D-0

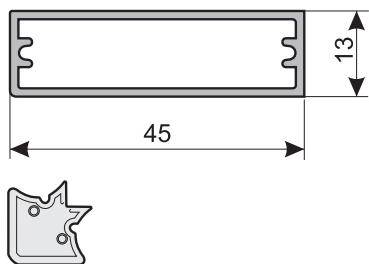

Kat. broj	Naziv
10.01.01	D-0
10.01.02	D-0
10.01.04	D-0

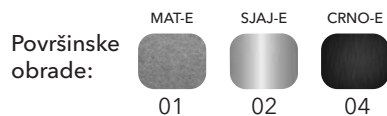

10.02. profil D-14

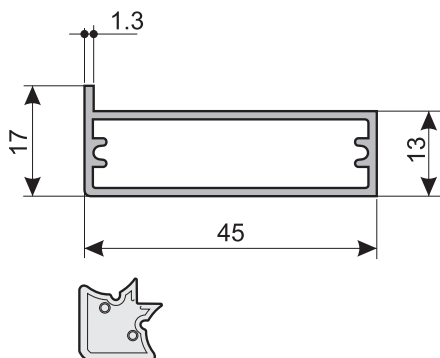

Kat. broj	Naziv
10.02.01	D-14
10.02.02	D-14
10.02.03	D-14
10.02.04	D-14

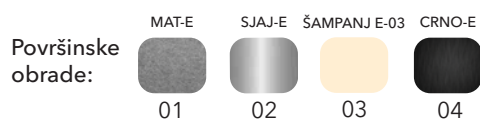

10.03. profil D-4

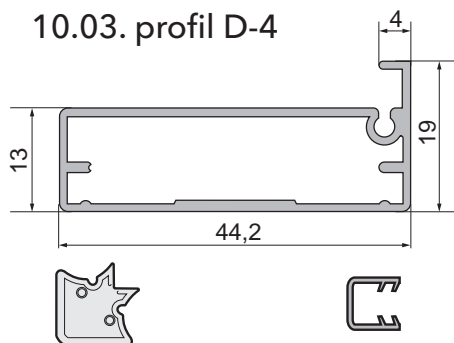

Kat. broj	Naziv
10.03.01	D-4
10.03.02	D-4
10.03.03	D-4



10.04. profil D-2

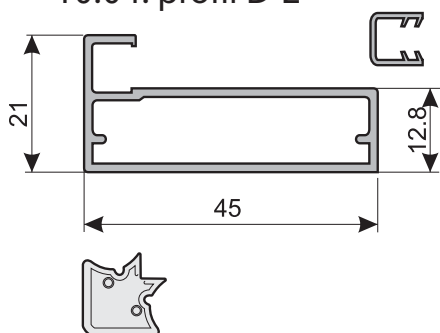

Kat. broj	Naziv
10.04.01	D-2
10.04.02	D-2
10.04.03	D-2



10.05. profil D-6

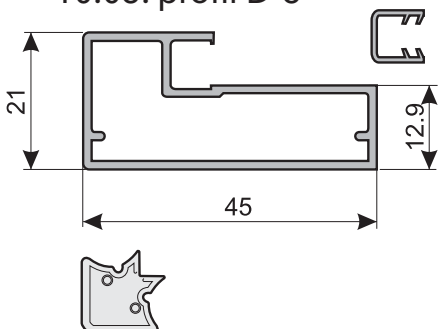

Kat. broj	Naziv
10.05.01	D-6
10.05.02	D-6
10.05.03	D-6
10.05.04	D-6

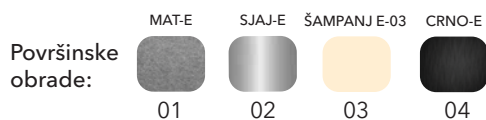

10.06. profil D-Quadro

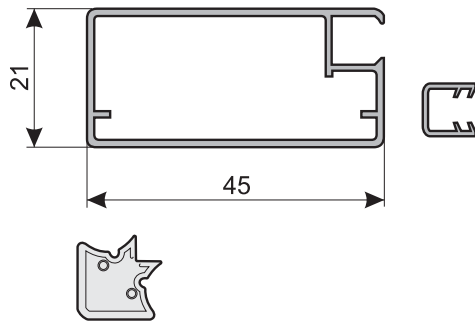

Kat. broj	Naziv
10.06.01	D-QUADRO

Površinske
obrade:  MATE
01

Alu ramovi

10.07. profil D-7

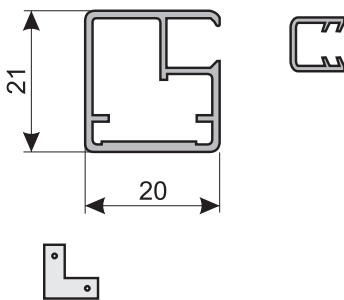

Kat. broj	Naziv
10.07.01	D-7

Površinske
obrade:  MATE
01

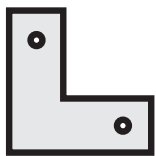

Kat. broj	Naziv
11.01.00	SET UGLOVA ZA D-7

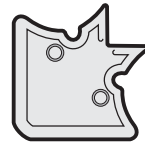

Kat. broj	Naziv
11.02.00	SET TL UGLOVA ZA ALU RAM



Kat. broj	Naziv
11.04.00	PLAST. ZAPTIKA ZA RAMOVE

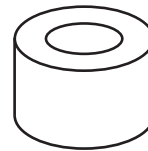

Kat. broj	Naziv
11.06.00	PLASTIČNI ODSTOJNIK



Kat. broj	Naziv
11.05.00	PLASTIČNA PODLOŠKA

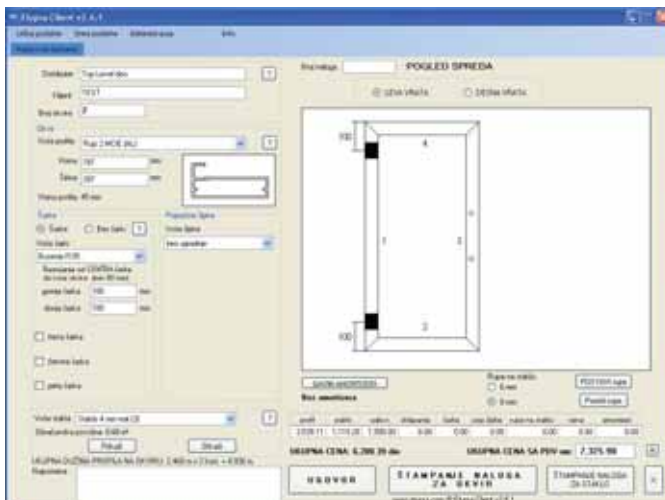

- Pomoću programa Elupra Client brzo i tačno možete naručiti ram željenih karakteristika.

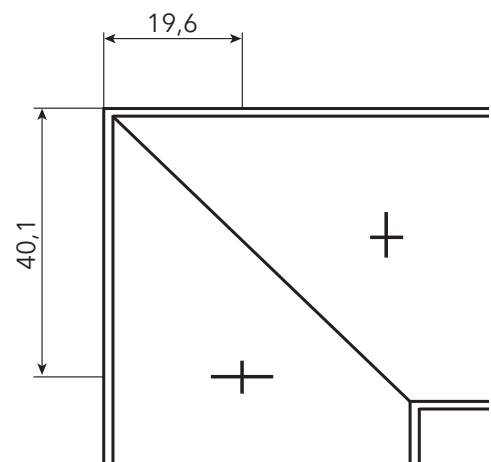

- Ugao za spajanje rama - kote bušenja

80. Nogice 40 x 40

Kat. broj	Naziv
80.02.05. 50.	TL NOGICA Cr BELA L 50
80.02.05. 80.	TL NOGICA Cr BELA L 80
80.02.05. 100.	TL NOGICA Cr BELA L 100
80.02.05. 120.	TL NOGICA Cr BELA L 120
80.02.05. 150.	TL NOGICA Cr BELA L 150
80.01.05. 50.	TL NOGICA MCrE BELA L 50
80.01.05. 80.	TL NOGICA MCrE BELA L 80
80.01.05. 100.	TL NOGICA MCrE BELA L 100
80.01.05. 120.	TL NOGICA MCrE BELA L 120
80.01.05. 150.	TL NOGICA MCrE BELA L 150
80.03.00. 50.	TL NOGICA ŠAMPANJ L 50
80.03.00. 80.	TL NOGICA ŠAMPANJ L 80
80.03.00. 100.	TL NOGICA ŠAMPANJ L 100
80.03.00. 120.	TL NOGICA ŠAMPANJ L 120
80.03.00. 150.	TL NOGICA ŠAMPANJ L 150

Kat. broj	Naziv
80.02.06. 50.	TL NOGICA Cr CRNA L 50
80.02.06. 80.	TL NOGICA Cr CRNA L 80
80.02.06. 100.	TL NOGICA Cr CRNA L 100
80.02.06. 120.	TL NOGICA Cr CRNA L 120
80.02.06. 150.	TL NOGICA Cr CRNA L 150
80.01.06. 50.	TL NOGICA MCrE CRNA L 50
80.01.06. 80.	TL NOGICA MCrE CRNA L 80
80.01.06. 100.	TL NOGICA MCrE CRNA L 100
80.01.06. 120.	TL NOGICA MCrE CRNA L 120
80.01.06. 150.	TL NOGICA MCrE CRNA L 150



81. Nogice 40 x 40

Kat. broj	Naziv
81.02.05. 60.	TL NOGICA Cr BELA PRSTEN L 60
81.02.05. 80.	TL NOGICA Cr BELA PRSTEN L 80
81.02.05. 100.	TL NOGICA Cr BELA PRSTEN L 100
81.02.05. 120.	TL NOGICA Cr BELA PRSTEN L 120
81.02.05. 150.	TL NOGICA Cr BELA PRSTEN L 150
81.01.05. 60.	TL NOGICA MCrE BELA PRSTEN L 60
81.01.05. 80.	TL NOGICA MCrE BELA PRSTEN L 80
81.01.05. 100.	TL NOGICA MCrE BELA PRSTEN L 100
81.01.05. 120.	TL NOGICA MCrE BELA PRSTEN L 120
81.01.05. 150.	TL NOGICA MCrE BELA PRSTEN L 150

Kat. broj	Naziv
81.02.06. 60.	TL NOGICA Cr CRNA PRSTEN L 60
81.02.06. 80.	TL NOGICA Cr CRNA PRSTEN L 80
81.02.06. 100.	TL NOGICA Cr CRNA PRSTEN L 100
81.02.06. 120.	TL NOGICA Cr CRNA PRSTEN L 120
81.02.06. 150.	TL NOGICA Cr CRNA PRSTEN L 150
81.01.06. 60.	TL NOGICA MCrE CRNA PRSTEN L 60
81.01.06. 80.	TL NOGICA MCrE CRNA PRSTEN L 80
81.01.06. 100.	TL NOGICA MCrE CRNA PRSTEN L 100
81.01.06. 120.	TL NOGICA MCrE CRNA PRSTEN L 120
81.01.06. 150.	TL NOGICA MCrE CRNA PRSTEN L 150

83. Nogice 40 x 40

Kat. broj	Naziv
83.00.01. 50.	NOGICA L-50 "QUADRA"
83.00.01. 80.	NOGICA L-80 "QUADRA"
83.00.01. 100.	NOGICA L-100 "QUADRA"
83.00.01. 120.	NOGICA L-120 "QUADRA"
83.00.01. 150.	NOGICA L-150 "QUADRA"



82. Nogice fi 40

Kat. broj	Naziv
82.02.05. 50.	TL NOGICA Cr BELA FI 40 L 50
82.02.05. 100.	TL NOGICA Cr BELA FI 40 L 100
82.01.05. 50.	TL NOGICA MCrE BELA FI 40 L 50
82.01.05. 100.	TL NOGICA MCrE BELA FI 40 L 100



90.05. VENTILACIONA REŠETKA



Kat. broj	Naziv	Kat. broj	Naziv
90.05.02.29	VENTILACIONA REŠETKA HROM 29	90.05.01.29	VENTILACIONA REŠETKA MAT 29
90.05.02.43	VENTILACIONA REŠETKA HROM 43	90.05.01.43	VENTILACIONA REŠETKA MAT 43
90.05.02.57	VENTILACIONA REŠETKA HROM 57	90.05.01.57	VENTILACIONA REŠETKA MAT 57
90.05.02.71	VENTILACIONA REŠETKA HROM 71	90.05.01.71	VENTILACIONA REŠETKA MAT 71
90.05.02.85	VENTILACIONA REŠETKA HROM 85	90.05.01.85	VENTILACIONA REŠETKA MAT 85
90.05.02.198	VENTILACIONA REŠETKA HROM 198 cm	90.05.01.198	VENTILACIONA REŠETKA MAT 198 cm
90.05.02.298	VENTILACIONA REŠETKA HROM 298 cm	90.05.01.298	VENTILACIONA REŠETKA MAT 298 cm

Površinske
obrade:



T LAJSNA 30 mm ZA RADNU PLOČU

Kat. broj	Naziv
92.01.01	T LAJSNA 4922 MAT 3 cm

Površinske
obrade:



T LAJSNA 40 mm ZA RADNU PLOČU

Kat. broj	Naziv
91.01.02	T LAJSNA 5494 HROM TIP 1
91.01.01	T LAJSNA 5494 MAT TIP 1
91.02.02	T LAJSNA 5494 HROM TIP 2
91.02.01	T LAJSNA 5494 MAT TIP 2

Površinske
obrade:



ZAVRŠNA LAJSNA 30 mm ZA RADNU PLOČU

Kat. broj	Naziv
93.01.01	ZAVRŠNA LAJSNA 30 MM-UNIVERZALNA

Površinske
obrade:



ZAVRŠNA LAJSNA 40 mm ZA RADNU PLOČU

Kat. broj	Naziv
94.01.01	ZAVRŠNA LAJSNA 40 MM-UNIVERZALNA TIP 1
94.02.01	ZAVRŠNA LAJSNA 40 MM-UNIVERZALNA TIP 2

Površinske
obrade:



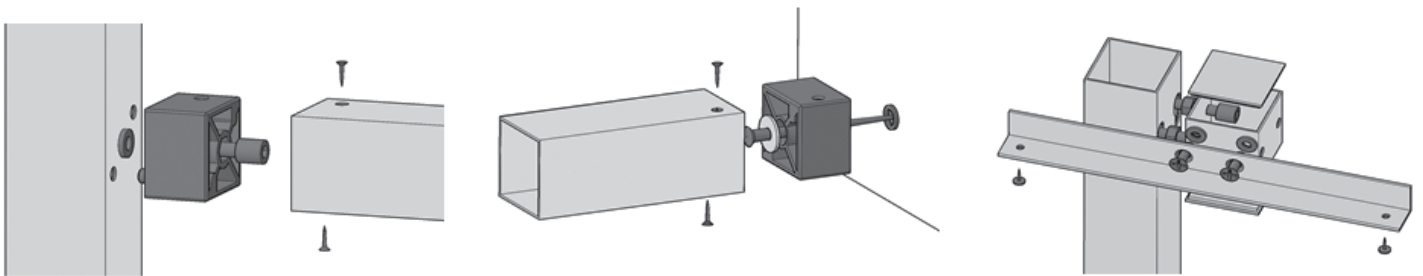



Kat. broj	Naziv
74.01.01.260.	TL VERTIKALA MAT
74.01.03.260.	TL VERTIKALA ŠAMPANJ

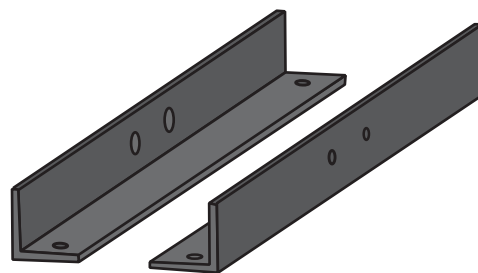
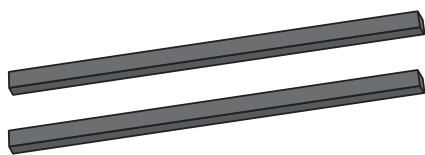

Kat. broj	Naziv
74.02.01.20.	TL MODUL DISTANCER 20 PAR MAT
74.02.03.20.	TL MODUL DISTANCER 20 PAR ŠAMPANJ
74.02.01.29.	TL MODUL DISTANCER 29 PAR MAT
74.02.03.29.	TL MODUL DISTANCER 29 PAR ŠAMPANJ

Kat. broj	Naziv
74.03.01.	NOSAČ POLICA MCrE
74.03.03.	NOSAČ POLICA MCrE ŠAMPANJ

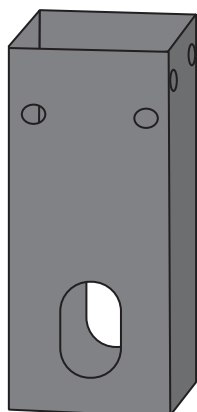

Kat. broj	Naziv
74.04.01.	NOSAČ OKLAGIJA SREDNJI MCrE
74.03.03.	NOSAČ OKLAGIJA SREDNJI ŠAMPANJ

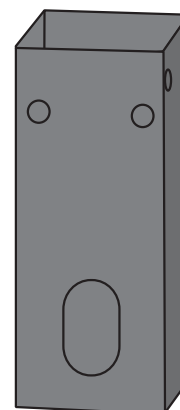

Kat. broj	Naziv
74.05.01.	NOSAČ OKLAGIJA KRAJNI MCrE
74.05.03.	NOSAČ OKLAGIJA KRAJNI ŠAMPANJ

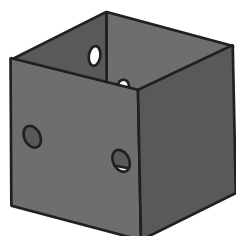

Kat. broj	Naziv
74.06.01.	PRIHVATNIK NOSAČA POLICE KRAJNI MCrE
74.06.03.	PRIHVATNIK NOSAČA POLICE KRAJNI ŠAMPANJ

Kat. broj	Naziv
74.07.01.	PRIHVATNIK NOSAČA POLICE SREDNJI MCrE
74.07.03.	PRIHVATNIK NOSAČA POLICE SREDNJI ŠAMPANJ

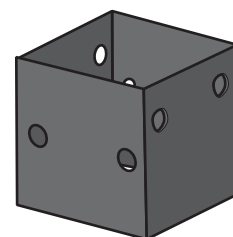

STANDARD PROFILI

Standard profili

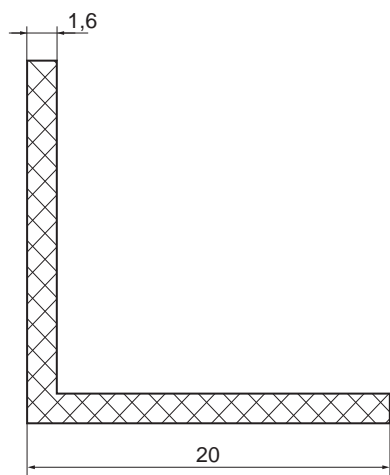
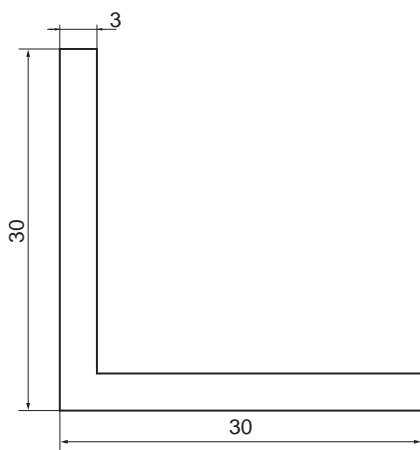
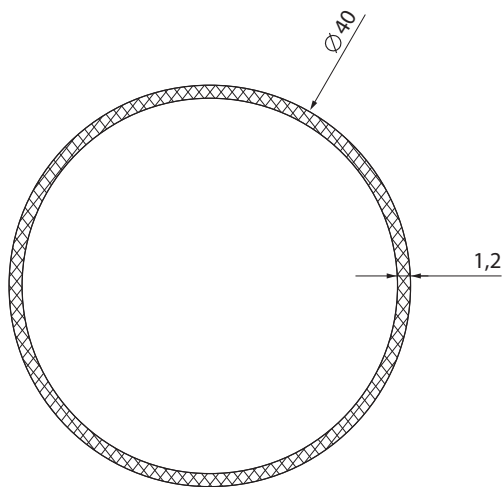
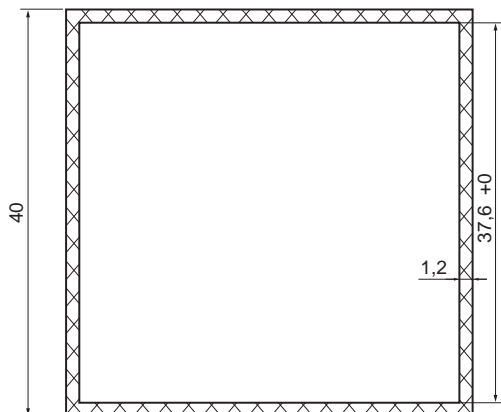

Kat. broj	Naziv
70.04.00-40x40	ALUMINIJUMSKI PROFIL 40X40 SIROVI
70.04.01-40x40	ALUMINIJUMSKI PROFIL 40X40 MAT
70.04.02-40x40	ALUMINIJUMSKI PROFIL 40X40 HROM
70.04.03-40x40	ALUMINIJUMSKI PROFIL 40X40 ŠAMPANJ

Površinske obrade:

MAT E-01



SJAJ E-02



ŠAMPANJ E-03



Kat. broj	Naziv
70.00.01.-fi40	ALUMINIJUMSKI PROFIL FI 40 MAT
70.00.02.-fi40	ALUMINIJUMSKI PROFIL FI 40 HROM

Površinske obrade:

MAT E-01



SJAJ E-02



Kat. broj	Naziv
70.02.01-30x30	ALUMINIJUMSKI L PROFIL 30X30 MAT

Površinske obrade:

MAT E-01



Kat. broj	Naziv
70.01.00-20x20	ALUMINIJUMSKI L PROFIL 20X 20 SIROVI
70.01.01-20x20	ALUMINIJUMSKI L PROFIL 20X20 MAT
70.01.03-20x20	ALUMINIJUMSKI L PROFIL 20X20 ŠAMPANJ

Površinske obrade:

SIROVI-00



MAT E-01



ŠAMPANJ E-03

